

# Lightscale F1 and Touring Car Air Boxes.



## 52023000

Air box F1, N.R.G., in black plastic

Air box for your Touring car is N.R.G., plastic, black colour, and the complete set includes all necessary accessories.

Lightscale N.R.G. is a high power, low noise and light weight air box system which fits all common known Touring car Models.

Its power is the result of it's big volume. Especially the area above the carburetor is optimized to guarantee the gas pillars `proper work (most important). The alloy adapter is molded concave which has shown the best results in many years of testing, while other ventura systems reduce the volume and result in less maximum rpm.

The Air Box outer part is made from robust fuel resistant plastic, which is impact resistant as well as flexible. This material is also part of the noise reduction system, ultra light weight without having to use fragile and expensive carbon fiber materials.

The incoming air is filtered with a foam piece just in front of the air intake and therefore as far as possible positioned from the carburetor intake. This fact also assists the power development and offers perfectly filtered air as well as easy access for maintenance.

As a result the use of Lightscales `N.R.G. Air box leads to a real gain of engine power and very importantly, torque for more pulling power and you get the benefit of longer engine life.

The set includes the fully pre mounted air box with adapter and pre oiled filter foam

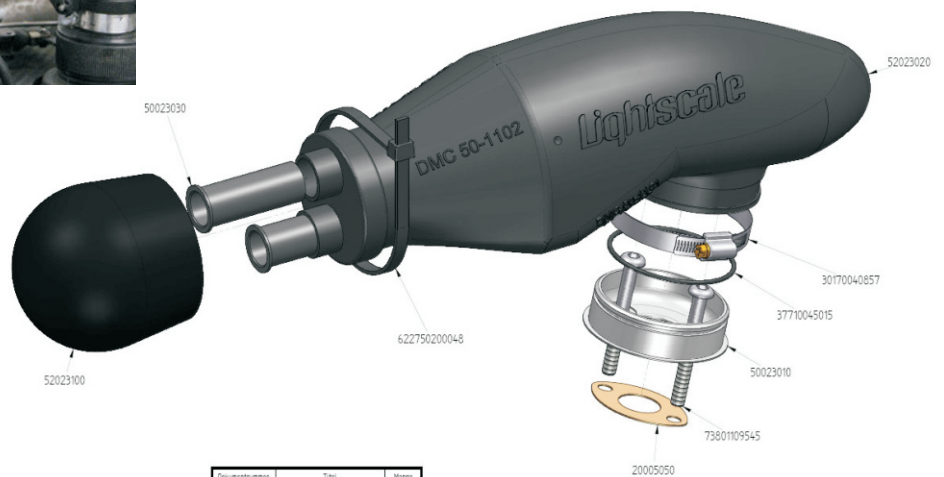

Dokumentnummer	Titel	Menge
20005050	Airboxdichtung 25-w7	1
50023010	Lightscale Airbox Adapter	1
50023030	Lightscale Airboxadapter für Airbox	2
52023020	Lightscale Airbox Gehäuse Tw	1
52023000	Lightscale Airbox Filterkorb	1
30170040857	Schraubenschlüssel M2 40-57	1
37710045015	U-Ring 45x15	1
73801109545	DN 7380 - M5 x 40	2
622750200048	Kegelbolzen 4.8-Ø20mm schwarz	1

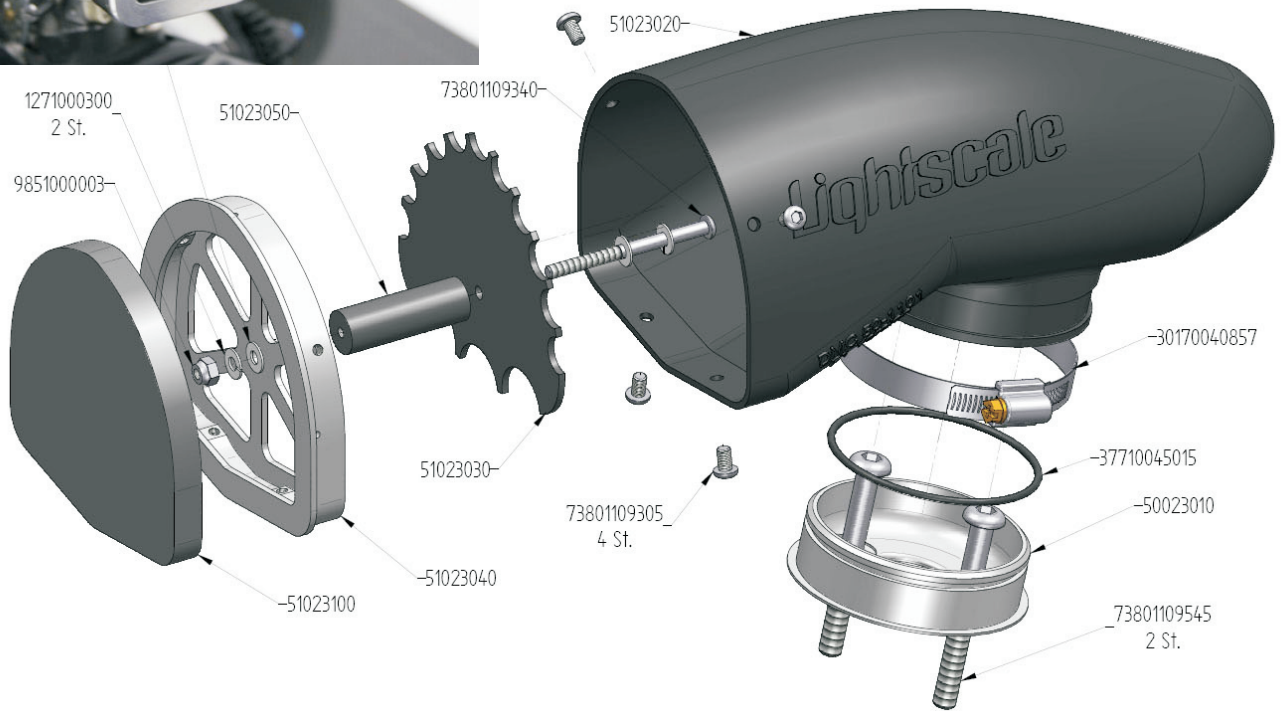

Air box F1, N.R.G., plastic, black colour, complete set including all necessary accessories. Lightscale N.R.G. is the first F1 Air box which together combines high power, low noise and light weight in one part.

Its power is the result of it's big volume. The box fits precisely the silhouette of the body shell and makes use of the full volume the Lightscale F1 body offers.

An integrated deflector absorbs the engines sound and reduces the noise level while it simultaneously slows down the airflow to a consistent level.

The Air Box outer part is made from robust fuel resistant plastic, which is impact resistant as well as flexible. This material is also part of the noise reduction system, ultra light weight without having to use fragile and expensive carbon fiber materials.

The incoming air is filtered with a foam piece just in front of the air intake and therefore as far as possible positioned from the carburetor intake. This fact also assists the power development and offers perfectly filtered air as well as easy access for maintenance.

As a result the use of Lightscales`N.R.G. Air box leads to a real gain of power and longer engine lifetime.

**!! ATTENTION !!** the N.R.G. box can be used in combination with Lightscale Silhouette only, as this is the only body shell which offers enough space to cover the air box.

Depending on the brand of car the use of a non standard isolator might not be possible.

The set includes the fully pre mounted air box with adapter and pre oiled filter foam.